

CITERM Heating Systems d.o.o.

MULTIFUEL oil burners

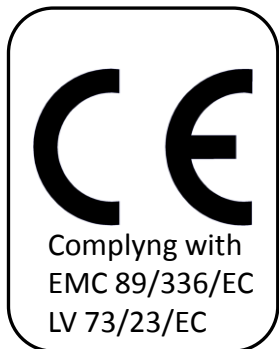
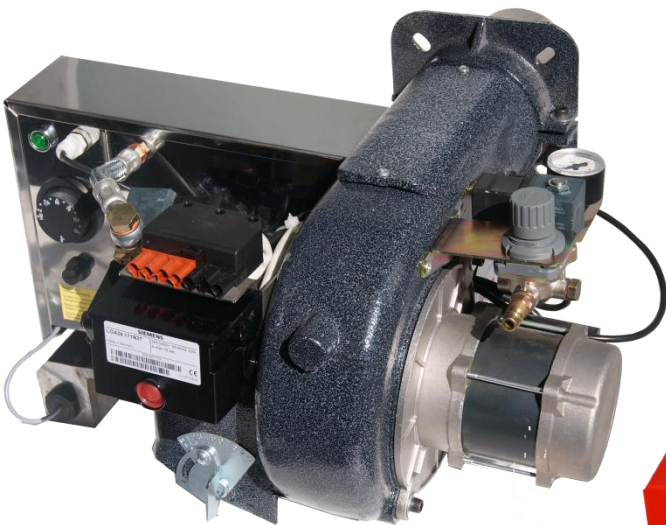

Table of Contents

1. Introduction.....	3
2. Safety warnings.....	3
3. General information.....	4
4. Fuels.....	4
5. Technical data.....	5
6. Burner dimensions.....	6
7. Boiler location.....	7
8. Function description.....	7
8. Installation.....	8
9. Flue connection.....	9
10. Safety and switching functions.....	10
11. Adjustments.....	11
12. Wiring diagram.....	12
13. Troubleshooting.....	13
14. Electrode adjustment.....	14
15. Burner pump.....	15-16
16. Maintenance.....	17-20
17. Parts drawing.....	21
18. Parts list.....	22
19. Main construction parts.....	23
20. Conformity declaration.....	24
21. Warranty.....	25



**Read the operation instructions carefully,
prior to installing and commissioning the heater**

- All details stated, referring installation and setting into operation must be effected and observed carefully in order to grant an economic operation free of malfunctions. Technical changes in the sense of product improvement reserved.

Introduction

INTRODUCTION

These burners are for commercial or industrial use.

The burners should be installed by an experienced installer specialized with the installation of oil-fired appliances.

If you pay attention to the following hints, you will be a part of the big circle of satisfied users of:

CITERM MULTIFUEL OIL BURNERS

PRECAUTIONS

Waste oil may contain many foreign materials. Waste oil may also contain gasoline. Therefore, specific precautions on the handling and storage of waste oils are to be observed when using, cleaning and maintaining this heater. Use a screen in a funnel when pouring oil into storage tank to catch foreign material, i.e., gasket material and sealant fibers, etc.

WARNING: This appliance is not designated for use in hazardous atmospheres containing chlorinated or halogenated hydrocarbons. Do not expose this unit to rain or moisture.

These burners are designed to provide economic disposal of used oils. Used oil is an inconsistent fuel and may contain water and/or foreign materials which may cause the unit to shut down. A secondary source of heat should always be provided to the building.

WARNING: Do not attempt to burn any grade of gasoline, paint thinners, or non approved fluids. Adequate ventilation must be provided in any enclosure where storage tanks, pump or accessories are installed.

Identical to any gas or oil burning appliance, without adequate draft over the fire, the combustion gases cannot escape the appliance. The flame will lengthen resulting in overheated combustion chamber. Even if the heater is installed correctly and adequate draft. Burning used oil is similar to burning wood. A fine gray ash accumulates in the chamber and flue passage. This accumulation of ash will eventually affect the draft. It is important to remove this ash before the draft is affected.

WARNING: Collect and store your oil continuously and be aware that:
Water and Sludge are Not combustible! New motor oil does NOT burn!

VENTING: Failure to provide proper venting could result in death, serious injury, and/property damage. Units must be installed with a flue connection and a proper vent to the outside of the building. Safe operation of any oil-burning equipment requires a properly operating vent system, correct provision for combustion air, and regular maintenance and inspection.

WARNING: Any cases of consequential damage due to the failure of the space heaters and boilers during operation will be excluded.

WARNING: Turn off electric power to the unit before doing any service or maintenance on the burner.

General Information

Multifuel burner must be installed in compliance with a number of regulations and requirements. It is therefore the duty of the installer to be familiar with all applicable regulations and requirements. Installation, start-up and maintenance must be performed with care.

Before installing CITERM Multifuel burner, please check the items supplied for completeness.

Scope of supply:

G-Series: Burner, mounting flange, flange seal, 7-th pole connector (plug), 8 meters of flexible oil line, Filter (optional)

JUNIOR: Burner, mounting flange, flange seal, 7-th pole connector (plug), 5 meters of flexible oil Line, remote pump with flex oil line and suction floater and strainer

FUNCTIONAL DESCRIPTION

The combustible is pumped from the storage tank by a **Inbuilt pump** (remote pump-JUNIOR) into the **burner tank**.

A double **floating switch** regulates the level in the burner tank and turn off burner in case of overflowing.

Float **switch in overflow tank** stops the burner in case of spilling oil in the overflow tank. A **thermostat** regulates the oil in the burner tank and switches on the burner automatically as soon as the regulated temperature is reached. An additional overheat thermostat prevents overheating. A special nozzle draws the fuel, by using the passing **compressed air**, which serves as primary air for the combustion, and atomizes it.

The **combustion fan** delivers the secondary air that is mixed with the spray mist at the **flame ring**.

Thereby a perfect combustion and safe operating are guaranteed.

SIEMENS LOA 24 control box control all parts and monitor

The flame by photo-cell.

COMPRESSED AIR

The minimum supply pressure of **1,5 bar** might be controlled by a air pressure regulator. (see page 7)

FUELS

The universal oil burners are suitable for use with a variety of natural oils, mineral based oils and synthetic oils. On account of their viscosity, these oils are not in conformity with EN 267 for oil burners. **The burners are, therefore, not licensable.** An inspection to determine suitability for the selected fuel type must be performed by the operator prior to acceptance of the installation.

The design and degree of protection of the burner make it suitable for operation in enclosed rooms. When using synthetic oil - min. Mix it with 10% heating oil for start safety.

When use oil from plants - set oil temperature to „max“, because flash point is high.

When using heating oil EL – set oil temperature to „min“



Overflow tank

Technical data

Technical data		JUNIOR	JUNIOR	JUNIOR	GP	G1p	G1p+	G2p	G2p+	G3p	G3p+
Heat output	Kw	25-35	35-65	50-85	25-35	35-65	50-85	60-120	60-150	130-201	130-250
Fuel consumption	Kg/h	2,4-3,4	2,9-5,3	4,2-6,3	2,4-3,4	2,9-5,3	4,2-6,3	5,8-10,7	5,8-14,5	12,5-19,2	12,5-23,5
Motor data	V	230	230	230	230	230	230	230	230	230	230
	W	66	66	66	180	180	180	180	180	180	180
	A	0,52	0,52	0,52	1,2	1,2	1,2	1,2	1,2	1,2	1,2
Power cartridge heater	W	800			1000			1000			1300
Power supply	V	230			230			230			230
	W	1000			1200			1200			1500
	A	5			6			6			7
Rotation	Rpm	2800			2800			2800			2800
Weight	Kg	12			16			16,5	17	19	20
Primary air consumption	m ³ /h	3,1	5,2	6,5	3,1	5,2	6,5	13	18	24	28
Nozzles		30609-11	DA-2	30609-49	30609-11	DA-2	30609-49	2×DA-2	2×DA-2	3×DA-2	3×30609-49

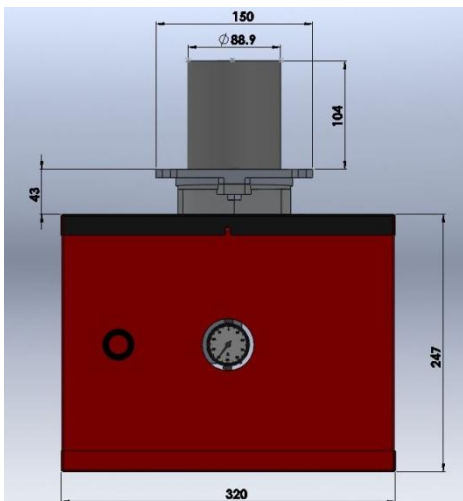
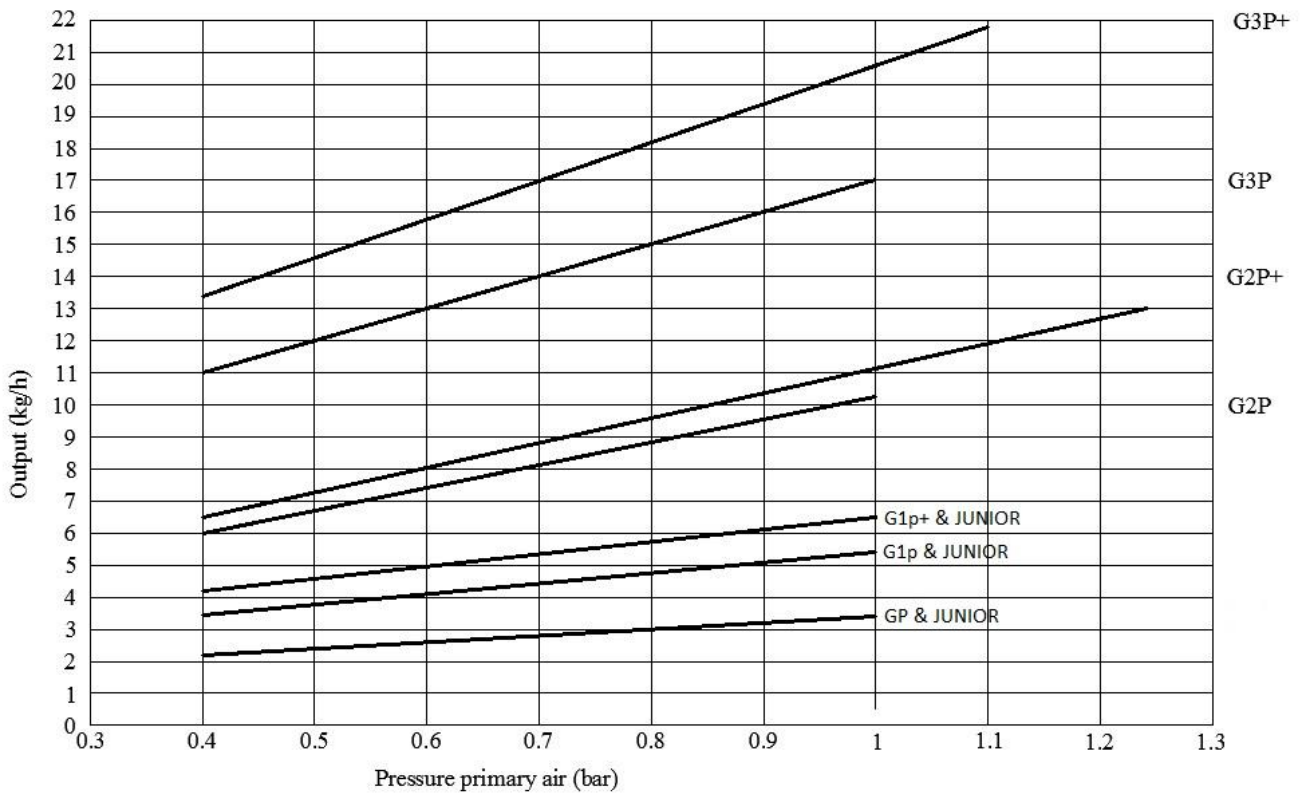

JUNIOR
Dimensiones

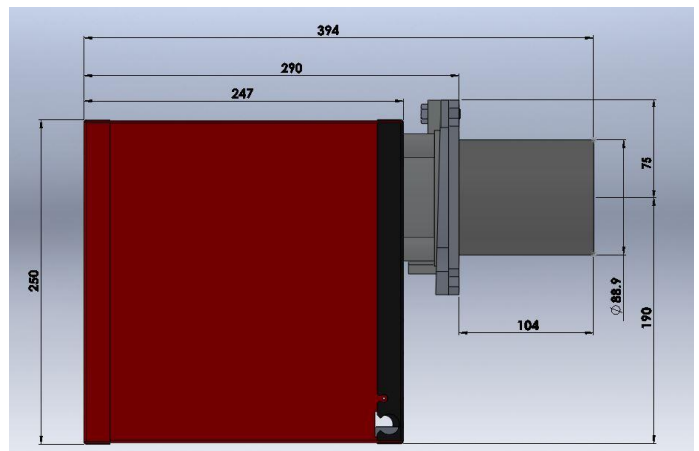

Dimensions

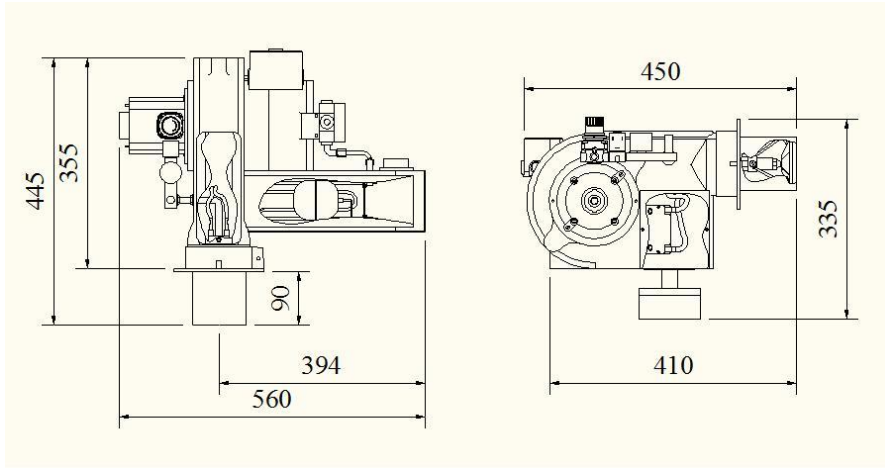

Gp & G1p

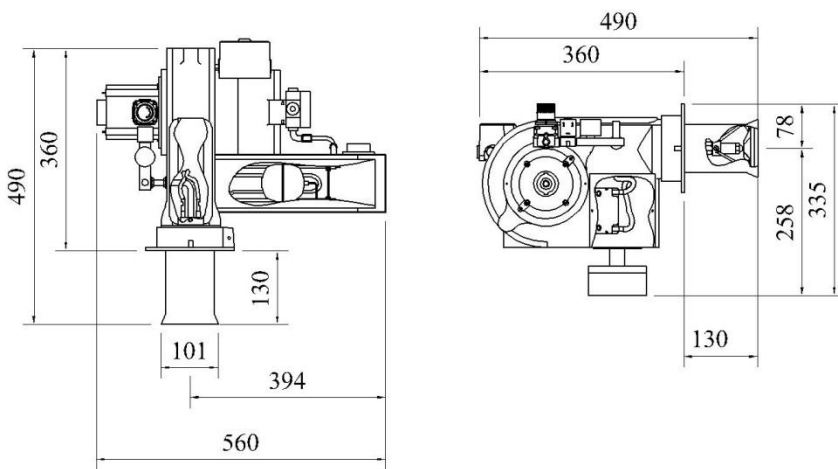

G2p & G2p+

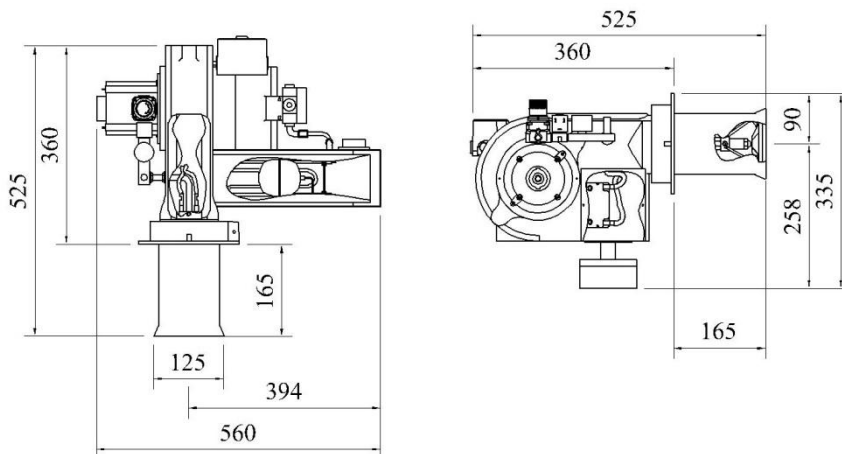

G3p & G3p+

Dimensions

Boiler location

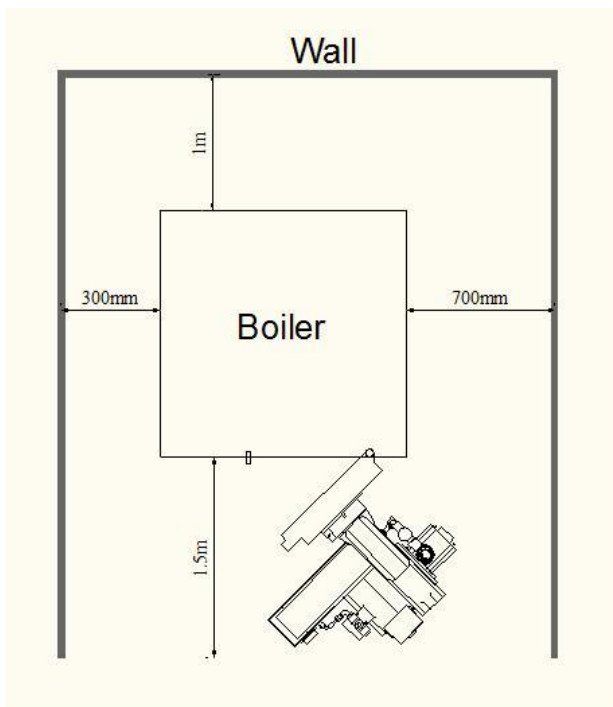

Air & oil flow schematic

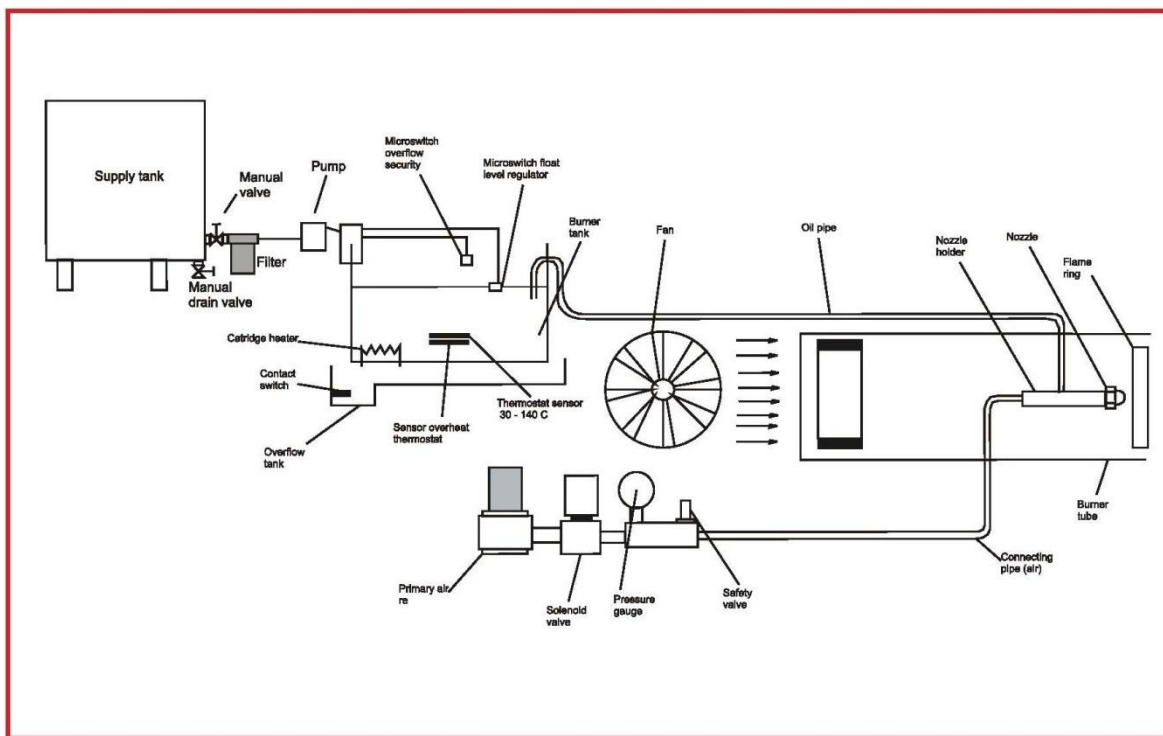

Installation

Connecting 7-th pin connector to power supply

- B4 - can be connected to hour meter
- S3 – signal for malfunction
- T1 & T2 – room thermostat
- F3 – Boiler thermostat

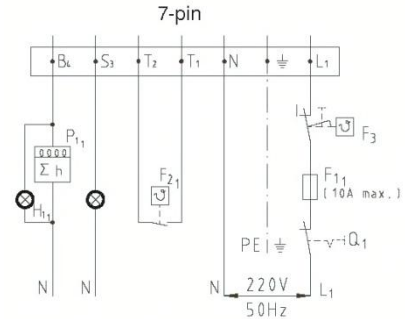

Compressed air inlet

Connect a compressed air line to the pressure regulator
 Be shore that air pressure is more then 1,5 bar
 The primary airflow should be set using the pressure regulator according to the required burner output. The information given in the diagram (page 5) can be used as guide values.
 Higher-viscosity fuels require higher air pressures

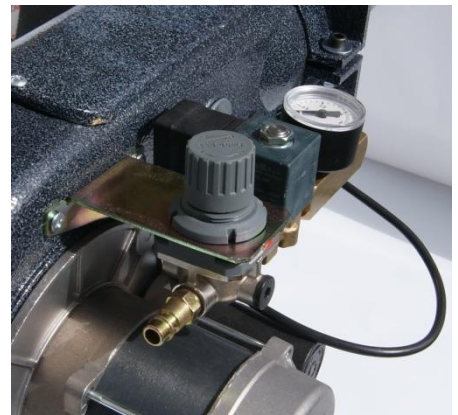

Oil pump

The oil pumps serve as delivery units, pumping oil into the burner tank. The atomization of the oil is not dependent on the oil pressure.
 Do not increase oil pressure under any circumstances!

- Connect 4 meters of oil pipe between return port and storage tank
- Connect 1 meter of oil pipe between inlet port and FAG filter 1"
- Connect 3 meters of oil pipe between FAG filter and storage tank

NEWER install inlet oil pipe to take oil from the bottom of the storage tank! Best solution is to use floating suction.

All water, sludge and other impurities are on the bottom! (they are more heavy then oil)
 Drain water from the storage tank once a month threw drain tap.

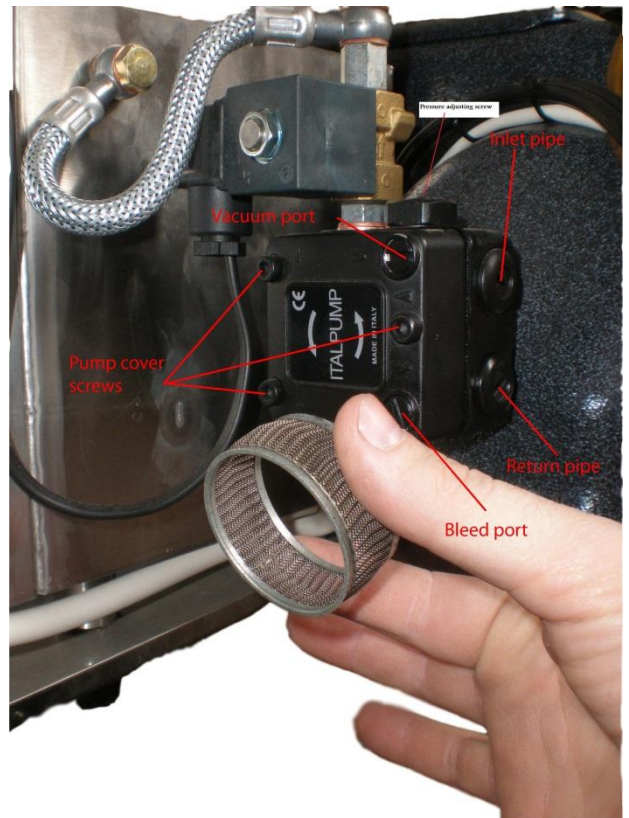

Installation

CAUTION: It is recommended that fuel be at a temperature of 5 degrees Celsius or higher when it enters the pump. At a temperature below 5 degrees Celsius oil becomes more viscous and difficult to pump. Supply of the burner tank may be reduced, resulting in nuisance shutdowns.

The storage tank should be no closer than 1,5m and no farther than 10m from the burner. If the tank is lower than the boiler and is more than 5m away from burner, then external pump must be used.

At the bottom of the supply tank manual valve must be installed (for water and sludge separation)

WARNING: Never install suction line at the bottom of the supply tank! Suction line must be fitted at 20cm higher from bottom.

SUPPLY LINES

Read this section carefully before installing any supply lines. Since a suction line leak is nearly impossible to find, **take your time to assure all connections are leak-free during installation.** Supply lines and fittings are furnished by the installer.

With the vacuum gauge mounted on the pump vacuum port, the gauge will indicate any suction line restriction, including a dirty filter.

All piping should be protected from possible damage and be rigidly fastened in place in workmanlike manner.

NOTE: Care must be exercised to ensure leak-free connections.

Flue connection

Important condition for perfect operation of the furnace is a correctly dimensioned flue.

Dimensioning is effected in accordance with DIN 4705 in consideration of DIN 18160 and based on the boiler and burner outputs.

The effective flue height is counted from burner level.

Select a flue design which minimizes the danger of condensation or of a cold flue inner wall.

For exact adjustment and stabilization of the flue draught we recommend the installation of a draught limiter.

By this means:

- any draught fluctuations are equalized
- moisture in the flue is largely excluded
- stoppage losses are reduced.

Connection pieces should be introduced into the flue with a gradient of 30° or 45° viewed in flow direction.

It is best to provide exhaust gas pipes with thermal insulation.

Exhaust gas thermometer

For exhaust gas temperature monitoring the heating system should be equipped with an exhaust gas thermometer.

The higher the exhaust gas temperature, the greater the exhaust gas loss.

Rising exhaust gas temperatures indicate increasing deposits of ash inside of combustion chamber, that will reduce the degree of combustion efficiency.

In the event of an increasing exhaust gas temperature have the heating installation cleaned (see picture) .



Safety and switching functions

Safety and switching functions

If a flame failure occurs during operation, the fuel feed shuts off immediately and the system tries a restart, with preventilation and retried ignition. If no flame results, the control box indicates a fault after the safety period expires. A restart takes place in all cases following a mains power failure. The control box shows a fault if the photoelectric cell detects a light source during the preventilation time, after the safety time.

The control device may only be plugged in or unplugged, if the main switch is in the "OFF" position or if the 7-pin plug connector is disconnected, because the bottom part of the control device carries 230 V.

External light on the photo-cell or flame detector must be prevented (e.g. red-hot fireclay lining). Only then is fault-free operation of the installation ensured.

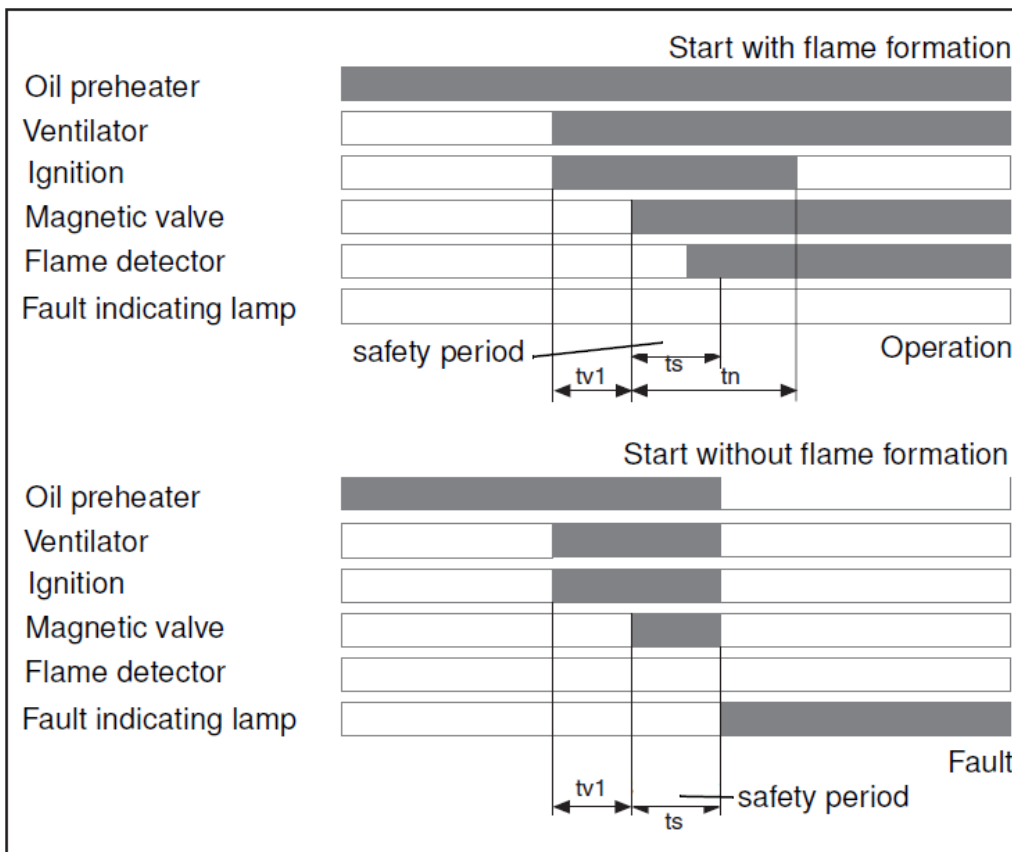

SIEMENS	LOA 24.171B27
t_{v1} = pre-ignition time + pre-ventilation	13 sec.
t_s = safety period	10 sec.
t_n = post ignition time	20 sec.
Post-ventilation after flame cut-off	-
Delay after switching-off fault	Approx. 60 sec.
Photo cell (flame sensor)	SIEMENS QRB1

Adjustments

Primary and secondary air adjustments

Burner type	Nozzle	Primary air	Secondary air
GP	1x30609-11	0,7	1,5
G1P	1xDA-2	0,9	2
G2P	2xDA-2	0,9	3,5
G2P+	2xDA-2	1,2	3,5
G3P	3xDA-2	1,2	4

Burner type	Nozzle	Primary air	Secondary air
JUNIOR	30609-11	0,6	4
JUNIOR	DA-2	0,8	5
JUNIOR	30609-49	0,9	7



Secondary air regulator (air dumper) G-series

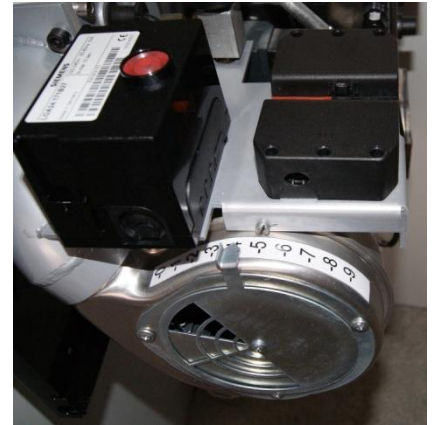

Secondary air regulator (air dumper) JUNIOR

Adjustment thermostat	
Rape seed oil	80-140 C°
Multi oil	90-120 C°
Heating EL/ Diesel	0 C° (not to heat)



Primary air pressure regulator



Adjusting thermostat

When setting burner for the first time into operation, fill burner tank with combustion manual. Normal oil level is 50mm from the top. **If you fill it more, overflow switch will turn off burner!**



Wiring diagram

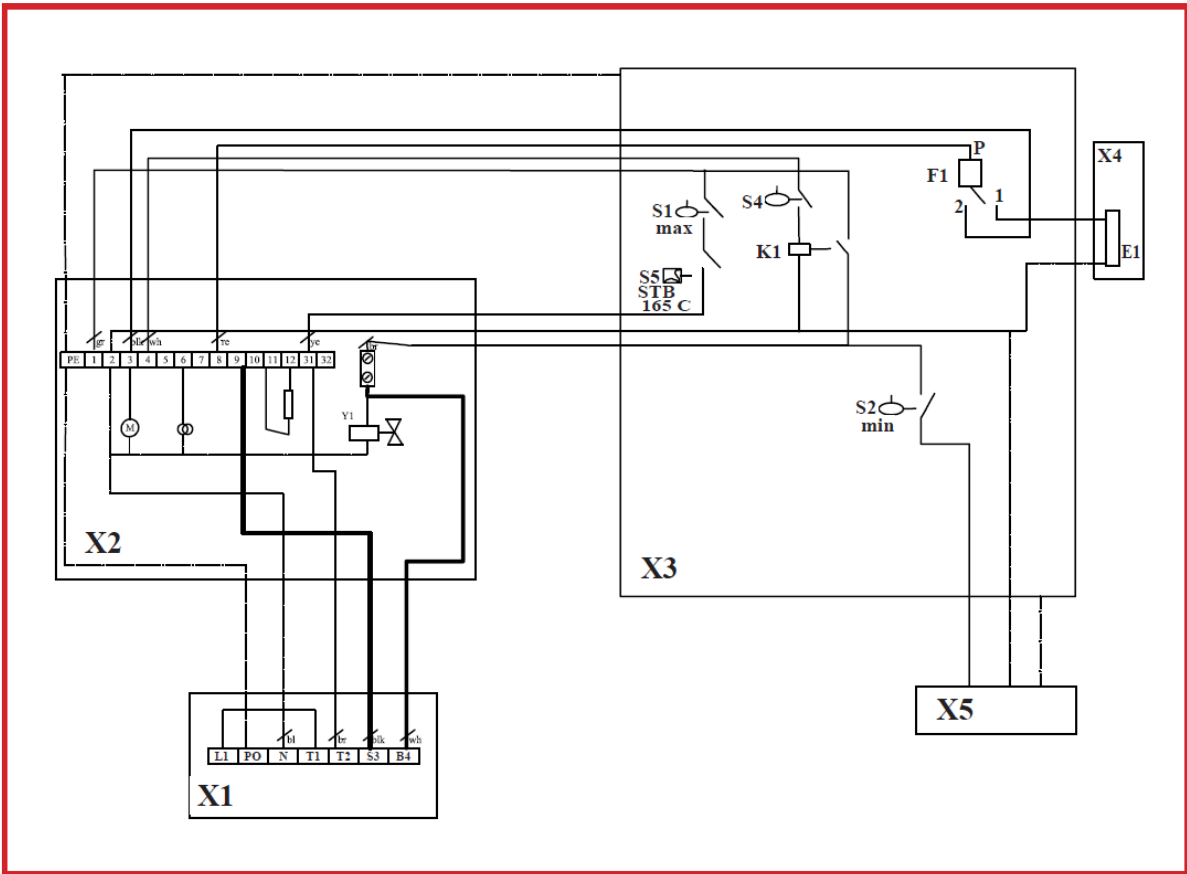

- B1** Cad cell
- E1** Heating coil 1100W
- F1** Regulating thermostat oil
- K1** Relay
- M1** Burner motor
- S1** Micro switch overflow security tank
- S2** Micro switch niveau regulation (min)
- S4** Overflow security overflow tank
- S5** Overheat thermostat OI
- T1** Transformer
- Y1** Solenoid valve
- X1** Burner plug
- X2** Socket burner control
- X3** Control burner oil tank
- X4** Oil tank
- X5** Pump solenoid valve or feeding aggregate

bl	blue
br	brown
ye	yellow
gr	green
blk	black
re	red
wh	white

Troubleshooting

Malfunction	Possible Cause	Remedy
Burner does not ignite or Flame interrupts and stops	a Heating oil is not combustible due to sludge or water contamination b Oil tank empty c Oil level in burn tank too high d Oil level in burner tank too low e Filter, feeding pump filter clogged, oil or air pipes defective f Solenoid valve feedingpump defective g Nozzle clogged or defective h Feeding pump blocked i No current j Motor defective k Overheat thermostat has triggered l Overheat thermostat continues triggering m Photo cell dirty or not pluggend in correctly n Burner control defective o No ignition p No comresed air q Compressed air too iow r Solenoid valve defective s Compressor or air pipe defective t Oil too viscous from frost u Distance between storage tank and burner to long v Burner too big or set too high	a Poen drain tap of burner tank. Drain sludge and water or use better heating oil b Refill with oil c Correct oil level by draining through drain tap and readjust if necessary. Float-switch leve setting d Correct oil level (refill) Clean feeding pump filter e Clean filter, feeding pump filter and pipes or repair f Check or raplace solenoid valve feedingpump g Clean or replace nozzle h Remove feeding pumpand clean gear wheel i Switch on plug coupling at burner to heater j replace motor k Unlok overheat thermostat l Change temperature regulator m Clean photo cell, plug it in correctly, replace if defective n Replace burner control o Adjust ignition electrodes and replace if necessary. Check transformer and ignition leads p Conect compressed air and adjust pressure q Verify the compressed air at Compresor (not below 2 bar) r Check solenoid valve and replace if necessary s Check compressor and air pipe and repair it t Insulate tank and oil tubes u Mount an additional feeding pump v Replace oveheat thermostat at heater and reduce heat load of burner
Burner ignites to late	a Cartridge heater and thermocouple in burner tank incrused or defective	a Clean cartridge feeding and at thermo couple in burner tank or replace
No oil supply to the burner tank	a Feeding pump dirty b Filter at the suction line is clogged	a Clean feeding pump strainer b Clean filter
Nozzle clogged or carbonized	a Flame ring falsely set b Too muchor too less compressed air c Too little ventilation in the heating room	a Correct measuring of the flame ring b Correct gauge pressure c Make ventilation openings big enough

Each readjustment of quantity, primary or secondary air requires an exhaust measuring and adjustment to optimum values- see at „factory setting“

Electrode adjustment

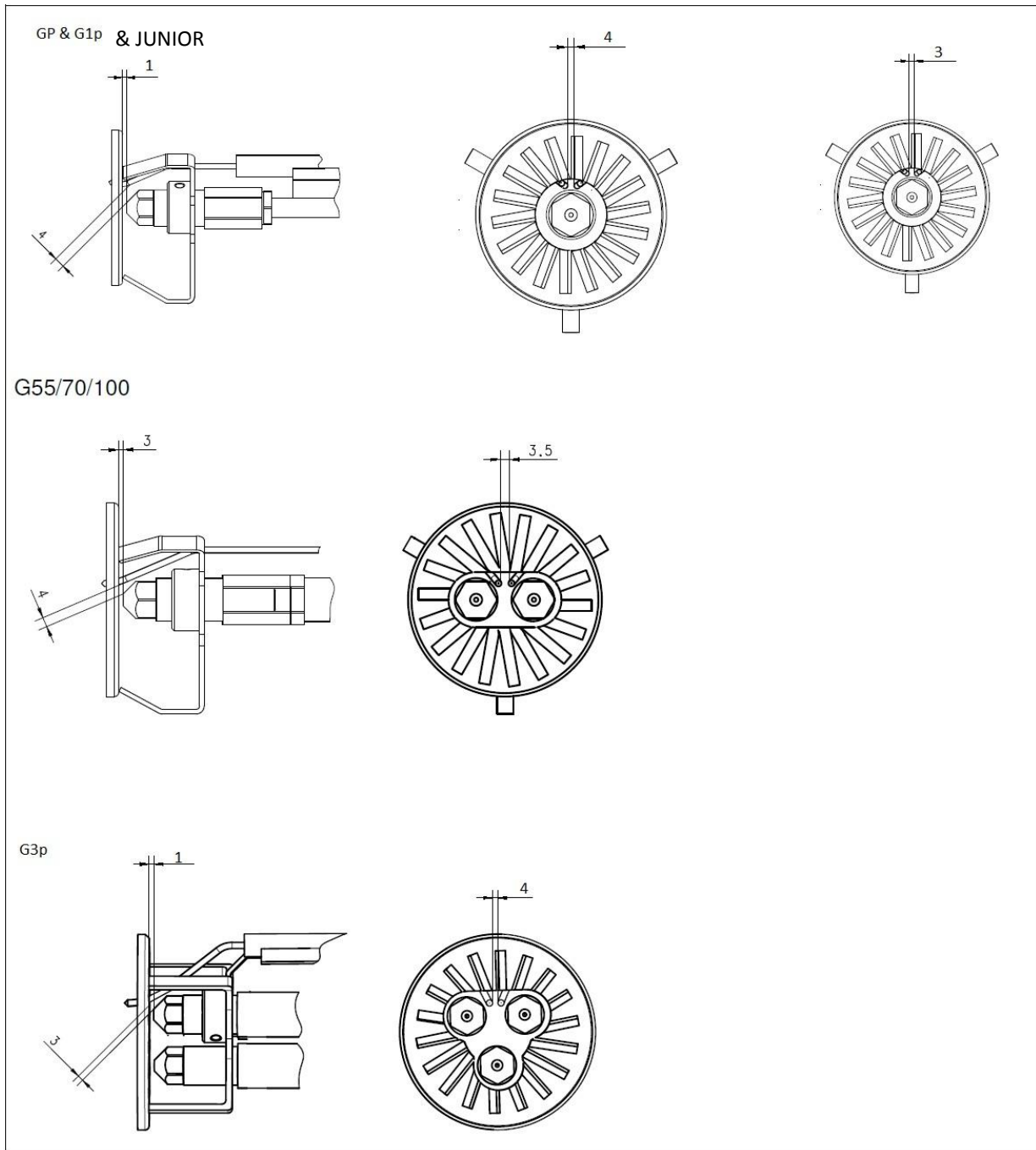

It is important to clean electrodes and flame ring monthly to achieve problem-free start.

CHARACTERISTICS

Applications:

- Heavy oil.
- One pipe and two pipes system.
- Self-priming.
- Manometer and vacuummeter connections.



FUNCTION

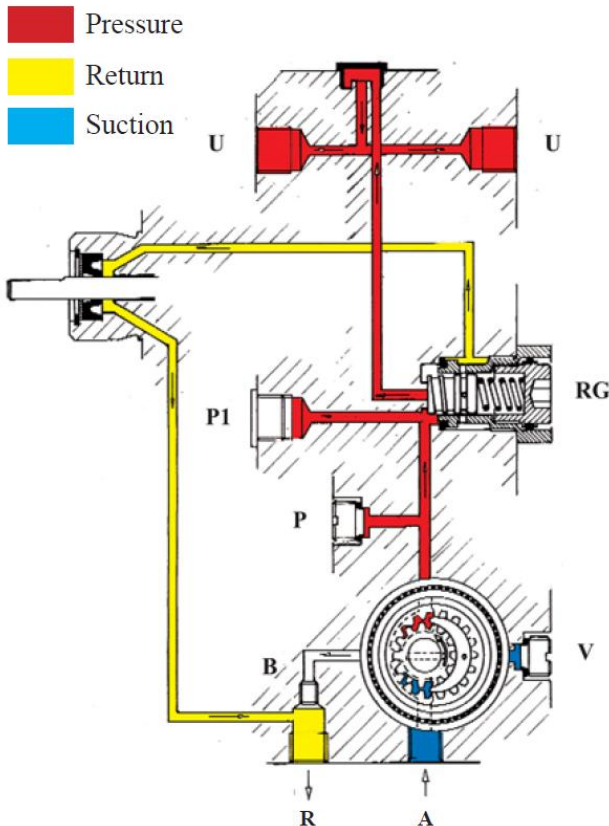

The suction vacuum generated by the gears sucks up the fuel through the suction line “A”; it crosses the filter and it is sent under pressure to the pressure adjustment screw “RG”.

The fuel is sent to the nozzle at the pressure value set by “RG”, only the exceeding fuel is sent on the return line “R”.

In the one-pipe system the by-pass screw “B” is removed and the return “R” is plugged; the whole fuel is sucked up by the gears without crossing another time through the filter. During the operation it is possible to measure the suction vacuum by the vacuum gauge port “V” and the pressure by the pressure gauge port “P”; it is also available on the pump an auxiliary delivery port “P1”.

When the burner stops, instantly the pressure comes down and the spring of the pressure adjustment screw “RG” moves the piston which stops the oil flow to the line and allows to the fluid to go through the return line “R”.

CONVERSION 2 PIPES - 1 PIPE SYSTEM

For the conversion proceed as follow:

- Remove the by-pass screw, located inside the return port “R”.
- Lock the return port with a steel plug G 1/4 and washer

ATTENTION:

In two-pipes system oil pump is self-priming, the bleding is obtained through the return line. In one-pipe system the return line is closed by plug, the bleeding must be obtained through the nozzle or opening the pressure gauge port “P”, to accelerate the way out of the air.

Burner pump

Power consumption-pressure Diagram

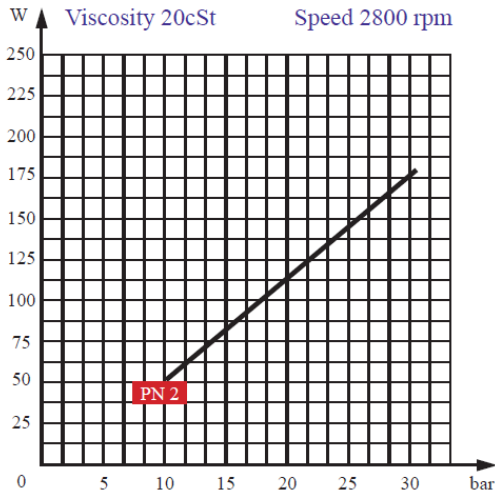

Pressure - capacity Diagram

Diagram considers a wear margin.

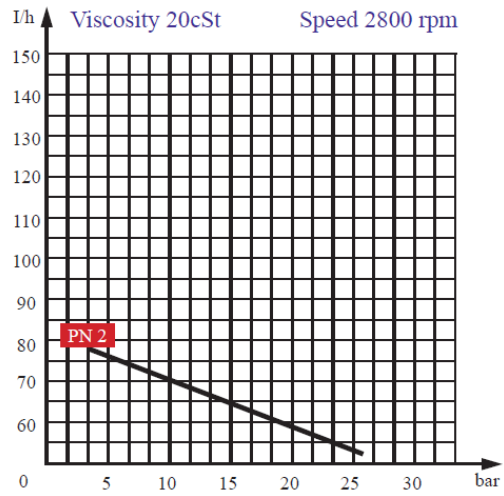

Hdraulic Data

Factory settings	15 bar
Pressure range	10 - 28 bar
Viscosity range	2 - 200 cSt
Oil temperature	0 - 120°C
Inlet pressure	1,5 bar max
Return pressure	1,5 bar max
Suction height	0,45 bar max
Speed	2800 - 3480 rpm
Starting torque	0,10 Nm
Capacity	see graphs
Power consumption	see graphs
Filter Open aria	11 cm ²
Mesh	300 µm
Weight	1,1 kg



Maintenance

Burner pump cleaning

If there is not enough oil in burner tank,
You must do next:

- Unscrew pump cover screws
- Clean metal strainer (see picture)
- Be careful not to damage gasket

Cleaning oil line

- Unscrew vacuum port screw
- Blow in with compressed air gun
- You will hear bubbles in the storage tank
- Screw back vacuum port screw
- Unscrew bleed port
- Turn the burner on
- When oil arrive, close bleed port.

SUPPLY LINES

Read this section carefully before installing any supply lines. Since a suction line leak is nearly impossible to find, **take your time to assure all connections are leak-free during installation.**

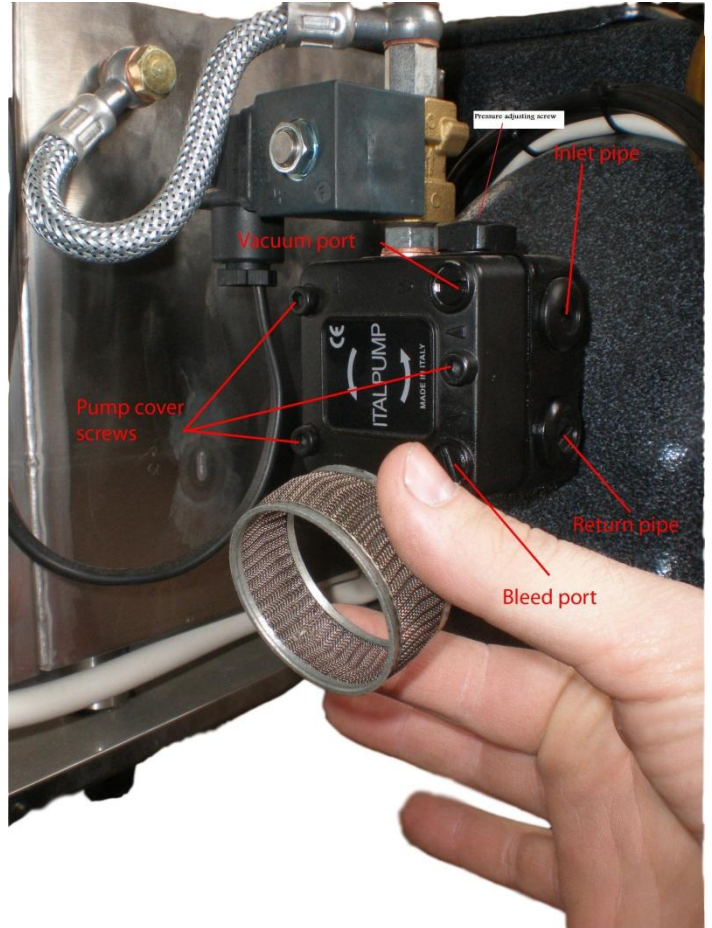

Always use liquid Teflon to seal all fittings
On the oil lines.
That is only way to prevent false air
coming into pump.
Always use clamps to tight oil pipes to fittings.



Maintenance

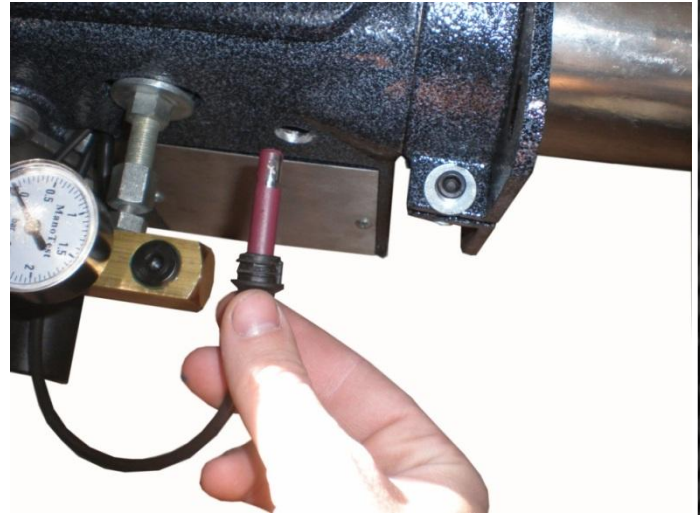

Photo-cell (flame sensor) must be cleaned every 30 days. If the photo-cell is dirty, burner will start flame and after 4 sec. Control box will show malfunction (red light will appear) Be careful to turn the photo cell to "see" the flame. (see picture)

Depending on the quality of the oil used, we recommend the following maintenance intervals:

Monthly:

- Clean the filter in the supply tank or the unit tank and strainer on the floating suction unit
- Check the oil level in the supply tank to be shore that enough fuel is available.
- Remove and clean the feed pump filter
- Remove sludge and residual water from the supply tank or unit tank
- The quantity can be determined by using water indication paste and a gauging rod
- Clean the photocell
- Clean the ignition electrodes and flame ring and blow out the nozzle with compressed air, check the spacing between the ignition electrodes (refer to checking dimensions for ignition electrodes page 14)
 - The electrode porcelain insulators must be free from carbon, oil, dirt, cracks. Otherwise, short circuiting could cause ignition problems.
 - Check boiler, if it is dirty, clean it.

Annually (before or after the heating period):

- Carry out monthly maintenance as described
- Clean the heating cartridges in the burner tank
- Clean the ignition electrodes and baffle plate, blow out the nozzle with compressed air and check the spacing between the ignition electrodes
- Clean the burner tank, supply tank and unit tank thoroughly.
- Clean the boiler and chimney.

Remote pump Instalation

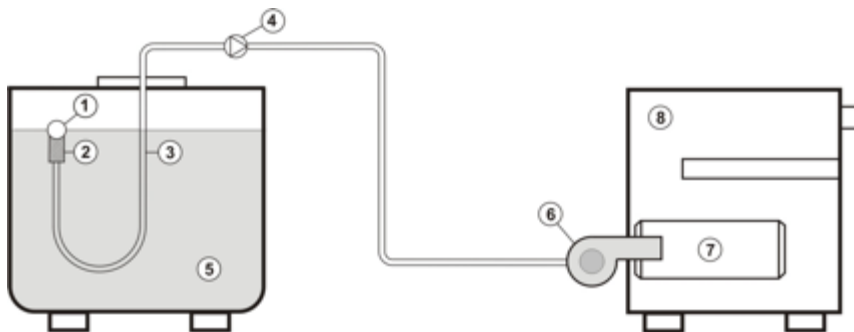

1. Floater
2. Strainer
3. Flexible oil line
4. Remote pump
5. Oil in the storage tank
6. Burner
7. Combustion chamber
8. Boiler

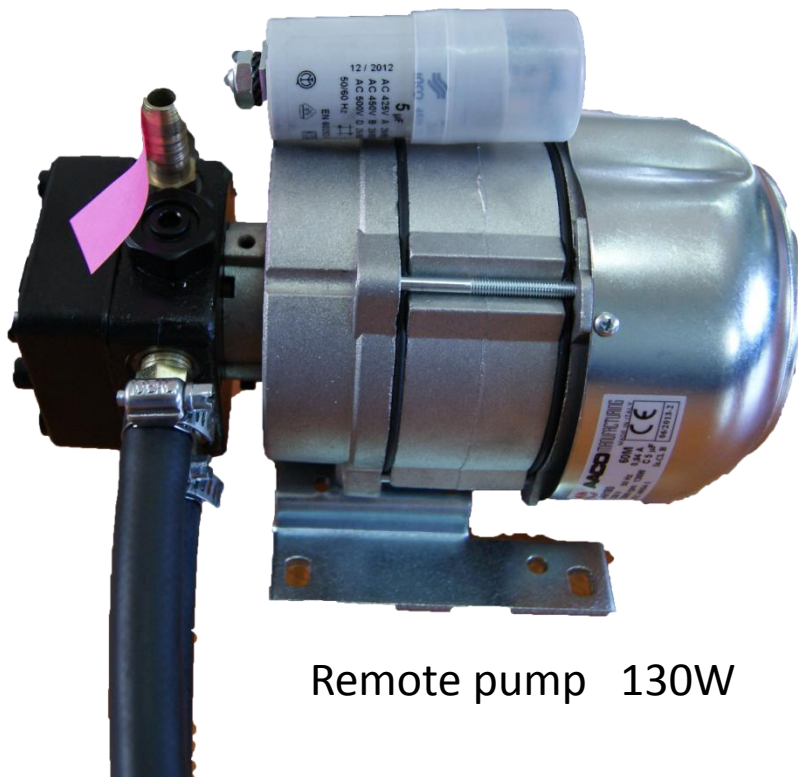

Remote pump 130W



Suction unit

Maintenance

Be careful when adjusting double switch!
 Normal fuel level is 50mm from the top of the heater.
 Safety contact must trigger if level raise to 25mm from the top of the heater.

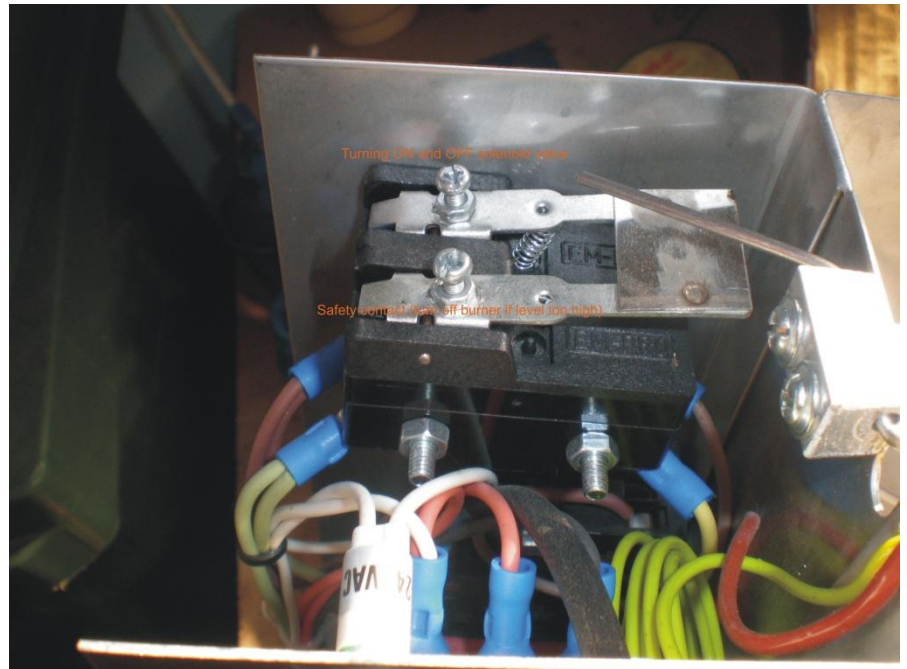

Ceramic fibre – necessary for all burners when used with steel boilers with large combustion chamber or cast-iron boilers with a vertical rear panel in the combustion chamber.
 Ceramic fibre will prevent making deposits of unburned oil at the bottom of the boiler.



Drain tap
 It is necessary to open drain tap
 To release settled water.

CITERM - G

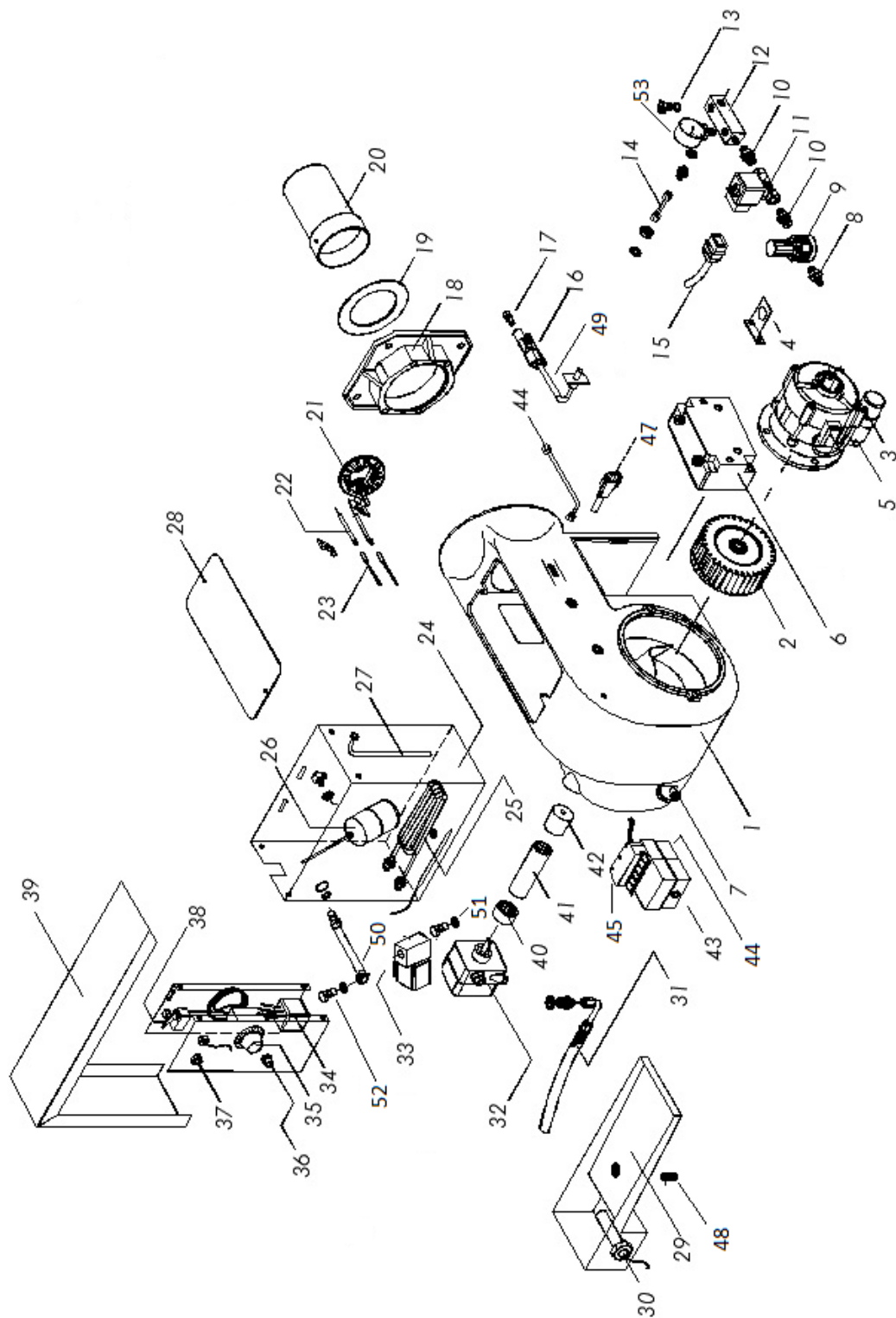

Part list

1. Burner body
2. Fan wheel
3. Condenser
4. Air pressure regulator holder
5. Motor
6. HT Transformer
7. Secondary air regulator (damper)
8. Compressed air plug-in fitting
9. Air pressure regulator
10. Nipple ¼- ¼
11. Solenoid valve air
12. Air distributor
13. 1/8 closing nut
14. 1/8 - 1/8 male-female fitting
15. Solenoid valve connector
16. Nozzle head
17. Nozzle
18. Burner flange
19. Flange gasket
20. Flame tube
21. Flame ring
22. Ignition electrode
23. HT cable
24. Burner tank
25. Heating cartridge
26. Floater
27. Copper pipe 1
28. Burner body lid
29. Overflow tank
30. Contact switch
31. Oil pipe
32. Oil pump
33. Solenoid valve oil
34. Relay
35. Regulating thermostat
36. Safety thermostat
37. Green light
38. Double adjustable switch
39. Tank lid
40. Plastic coupling 8mm
41. Rubber coupling 130mm
42. Plastic coupling 12,7mm
43. Control box
44. Base for control box
45. Socket 7-th pole
46. Plug 7-th pole
47. Photo cell
48. Drain tab
49. Pipe L-90 ¼ -1/8
50. Oil pipe O1/4 – 1/8
51. Nipple 1/8 -1/4
52. Hollow screw ¼
53. Pressure gauge

Main construction parts

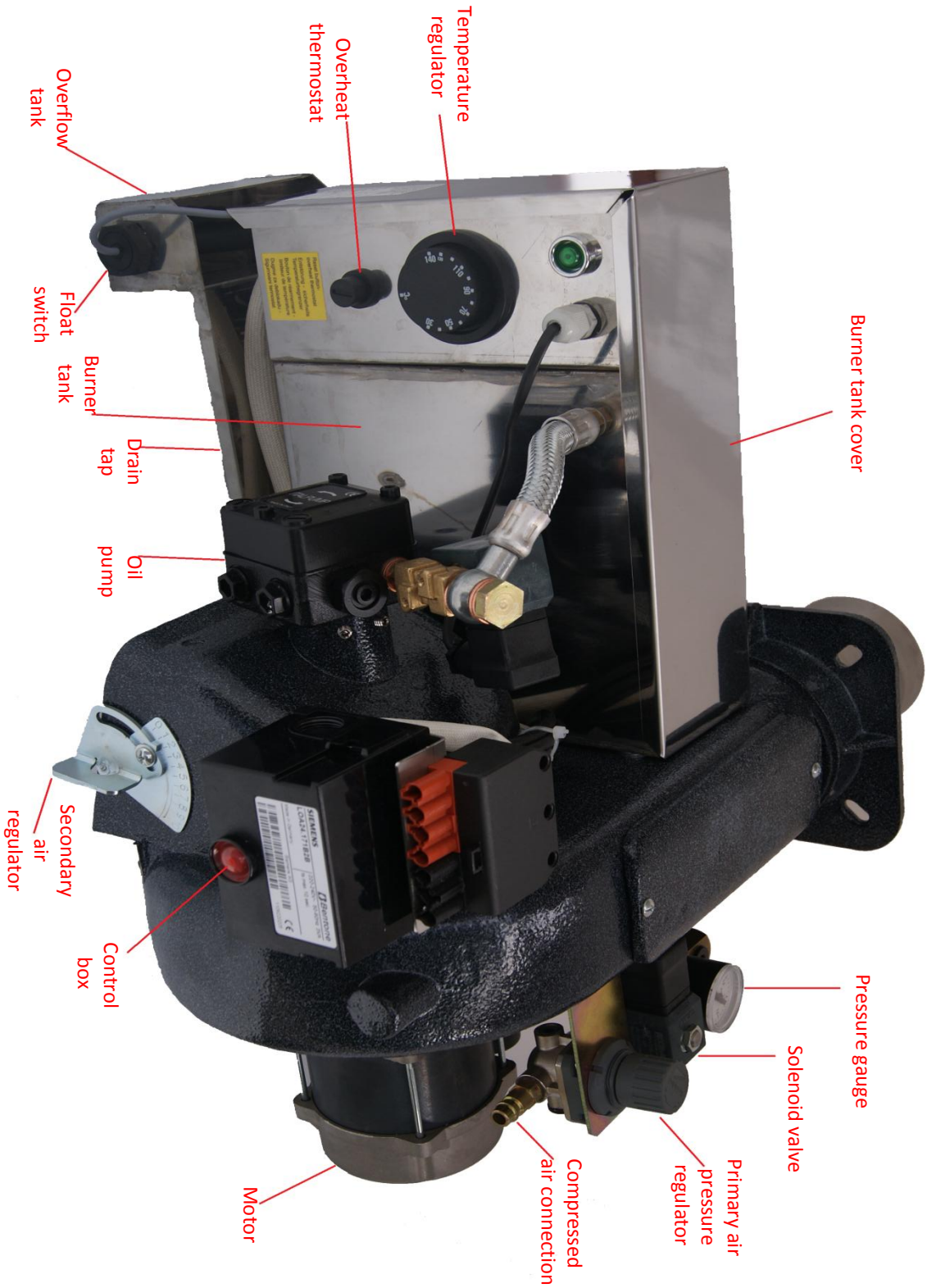

Conformity declaration

Conformity declaration

We declare, that the ventilated oil burners construction series **G** and **JUNIOR** are correspond to the basic demand of following directives:

- **Low tension directive** according 73/23/EC
in connection with VDE 0700 part 1 / version 04.88
and DIN VDE 0722 / version 04.83
- **Electrical safety**
according to DIN EN 50 165:2003 and EN 60335-1:2003
- **Electromagnetic compatibility according to EMC directive 89/336/EC**
in connection with EN 55014 / version 04.93
and EN 50082-1 / version 01.92
- **Machines directive** according directive 98 / 73 / EC



Milan Cincovic
Director

- The usual Warranty period granted on our devices cover 12 months after the delivery – the date of Invoice being decisive.
- Any cases of consequential damage due to the failure of the hot air generators and boilers during operation will be excluded.

WARRANTY IS VOID IF:

- Burner is not maintained in accordance with maintenance requirements.
- Wiring is not in accordance with circuit diagram
- EL fuel oil according to the DIN Standard No.51 603-1 is used at temperature below +4 C or if winter diesel is used below stipulated temperatures. (IT IS STRICTLY PROHIBITED TO ADD ANY PETROL!!!). The Burners must not be modified or tampered with under circumstances, and repair work must be carried out by a specialist.
- Without the proof of a technically correct delivery, any warranties from the side of the Company CITERM will lapse.
- If the pump pressure is set at a higher value, the motor will be overheated and may be damaged, excluding any warranties.
- The Warranty will only be granted if a regular servicing is carried out at least once a year in accordance with the CITERM operating instructions.